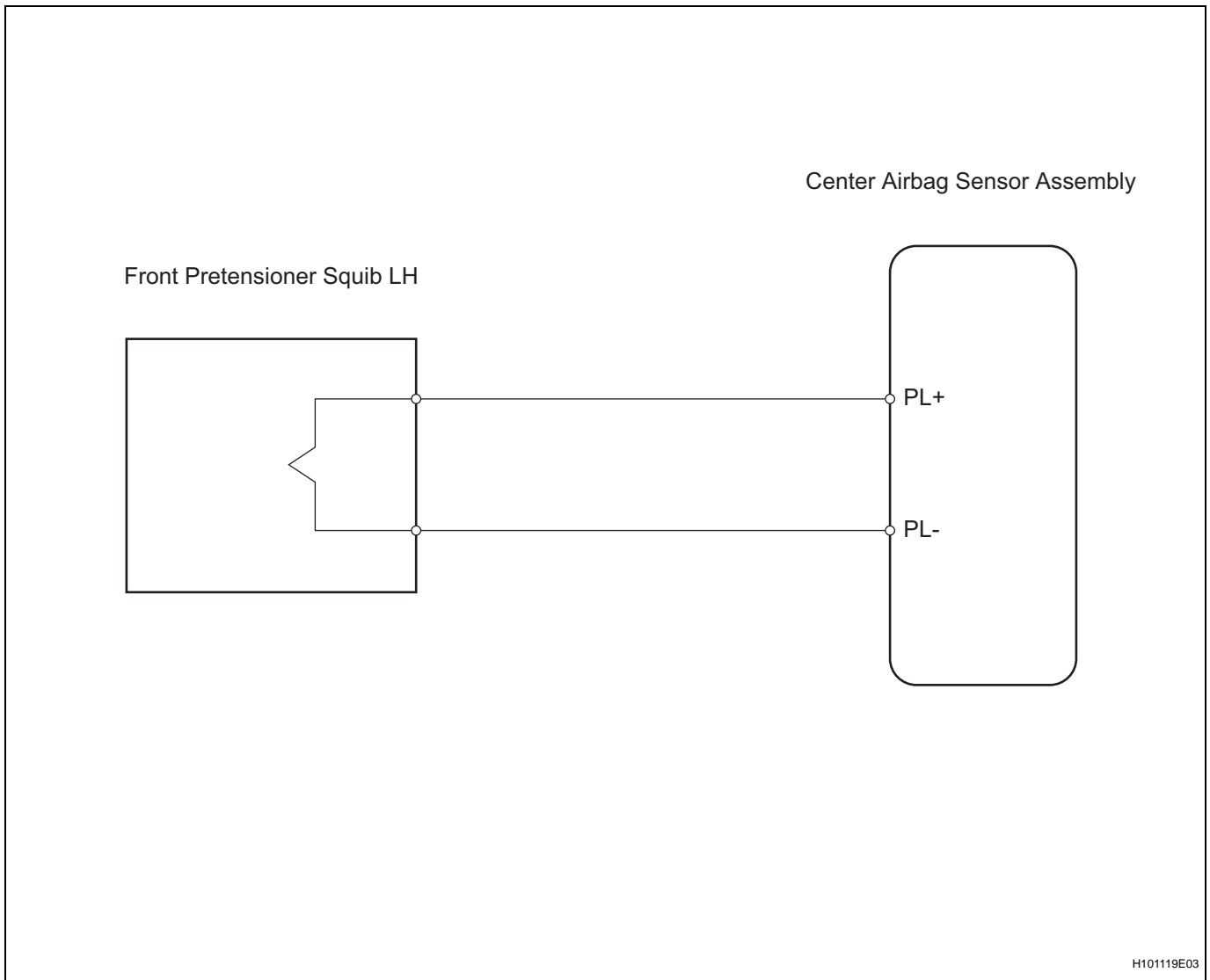

**DTC****B0136/74****Open in Front Pretensioner Squib LH Circuit****DESCRIPTION**

The front pretensioner squib LH circuit consists of the center airbag sensor assembly and the front seat outer belt assembly LH (seat belt pretensioner LH).

This circuit instructs the SRS to deploy when deployment conditions are met.

DTC B0136/74 is recorded when an open circuit is detected in the front pretensioner squib LH circuit.

**RS****WIRING DIAGRAM****1****CHECK FLOOR WIRE (FRONT PRETENSIONER SQUIB LH CIRCUIT)**

- (a) Turn the ignition switch to the LOCK position.
- (b) Disconnect the negative (-) terminal cable from the battery, and wait for at least 90 seconds.
- (c) Disconnect the connectors from the center airbag sensor assembly and the front seat outer belt assembly LH.

RS

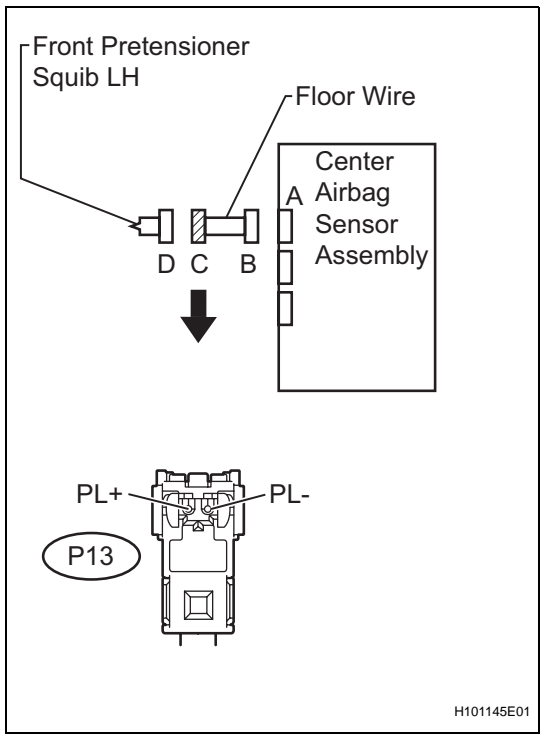

(d) Measure the resistance according to the value(s) in the table below.

**Standard resistance**

Tester Connection (Connector "C")	Specified Condition
P13-1 (PL+) - P13-2 (PL-)	Below 1 Ω

**NG** REPAIR OR REPLACE FLOOR WIRE

OK

**2 CHECK CENTER AIRBAG SENSOR ASSEMBLY**

(a) Connect the connector to the center airbag sensor assembly.

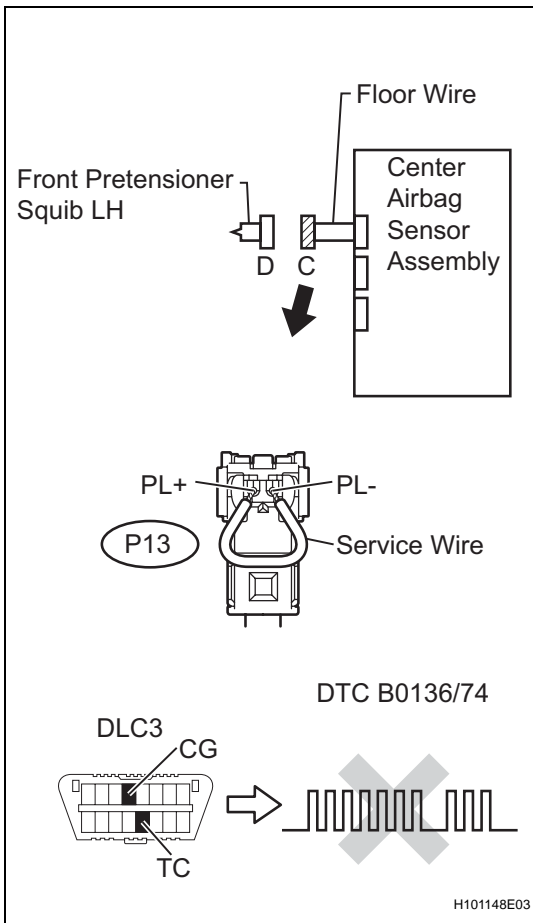

- (b) Using a service wire, connect terminals PL+ and PL- of connector "C".

**NOTICE:**

- **Twist the end of the service wire in order to insert to the connector.**
- **Do not forcibly insert the twisted service wire into the terminals of the connector when connecting.**

- (c) Connect the negative (-) terminal cable to the battery, and wait for at least 2 seconds.
- (d) Turn the ignition switch to the ON position, and wait for at least 60 seconds.
- (e) Clear the stored DTCs in the memory (see page RS-21).
- (f) Turn the ignition switch to the LOCK position.
- (g) Turn the ignition switch to the ON position, and wait for at least 60 seconds.
- (h) Check for the DTCs (see page RS-21).

**OK:**

**DTC B0136/74 is not output.**

**HINT:**

Codes other than code B0136/74 may be output at this time, but they are not related to this check.

**NG** → **REPLACE CENTER AIRBAG SENSOR ASSEMBLY**

**OK**

**3 CHECK FRONT SEAT OUTER BELT ASSEMBLY LH**

- (a) Turn the ignition switch to the LOCK position.
- (b) Disconnect the negative (-) terminal cable from the battery, and wait for at least 90 seconds.
- (c) Disconnect the service wire from the connector "C".
- (d) Connect the connector to the front seat outer belt assembly LH.
- (e) Connect the negative (-) terminal cable to the battery, and wait for at least 2 seconds.
- (f) Turn the ignition switch to the ON position, and wait for at least 60 seconds.
- (g) Clear the stored DTCs in the memory (see page RS-21).
- (h) Turn the ignition switch to the LOCK position.
- (i) Turn the ignition switch to the ON position, and wait for at least 60 seconds.

**RS**

RS

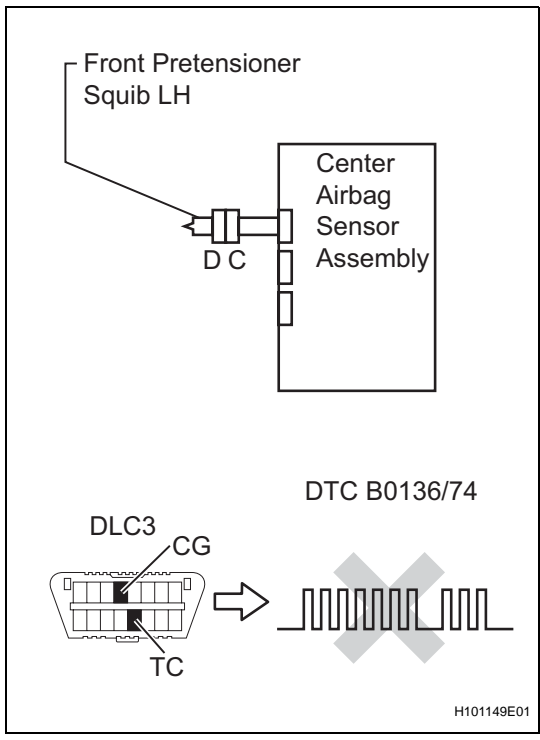

(j) Check for the DTCs (see page RS-21).

**OK:**

**DTC B0136/74 is not output.**

**HINT:**

Codes other than code B0136/74 may be output at this time, but they are not related to this check.

**NG**

**REPLACE FRONT SEAT OUTER BELT ASSEMBLY LH**

**OK**

**PROBLEM SYMPTOMS SIMULATION**