

ENGINE UNIT COMPONENTS

EM

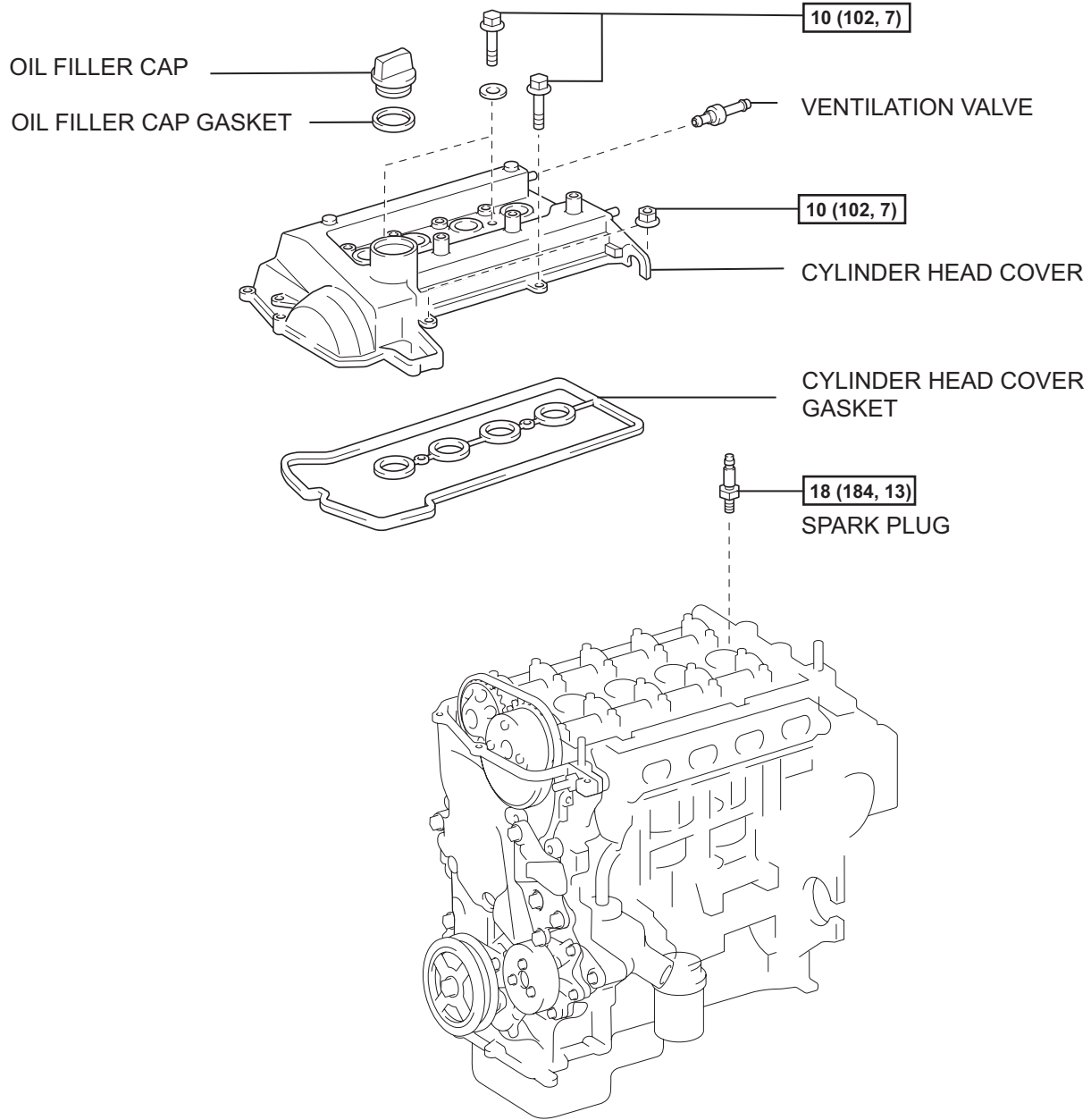

N*m (kgf*cm, ft.*lbf) : Specified torque

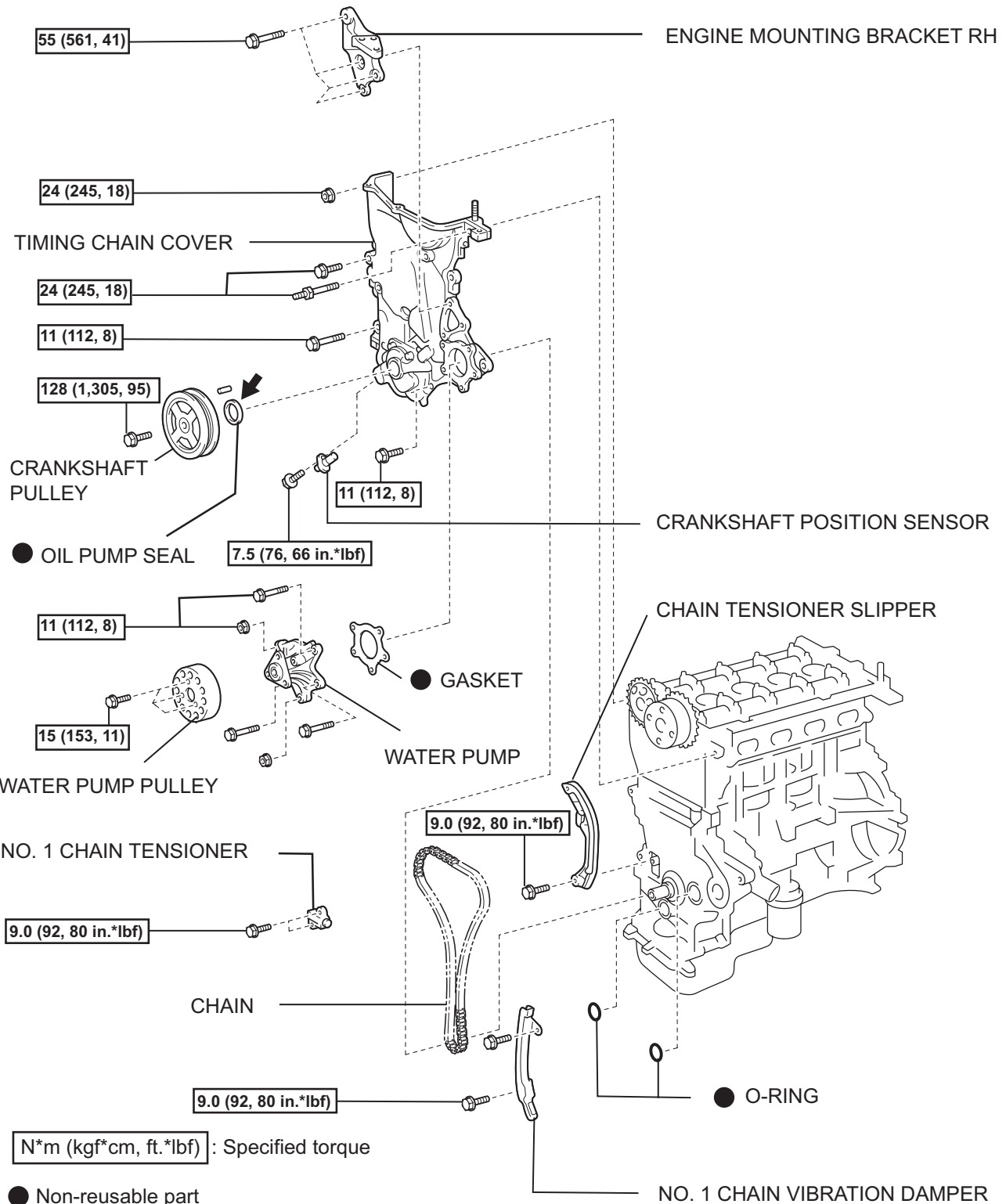

N*m (kgf*cm, ft.*lbf) : Specified torque

● Non-reusable part

← Apply MP grease

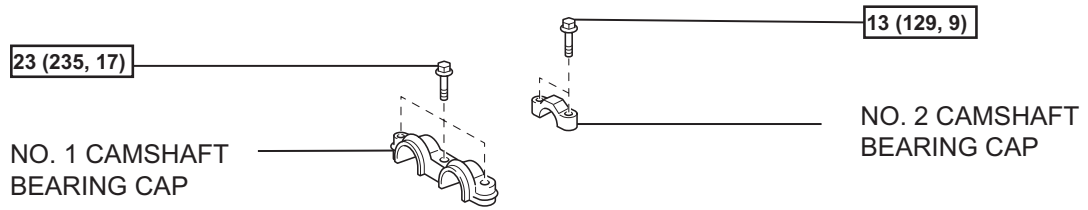

CAMSHAFT TIMING SPROCKET

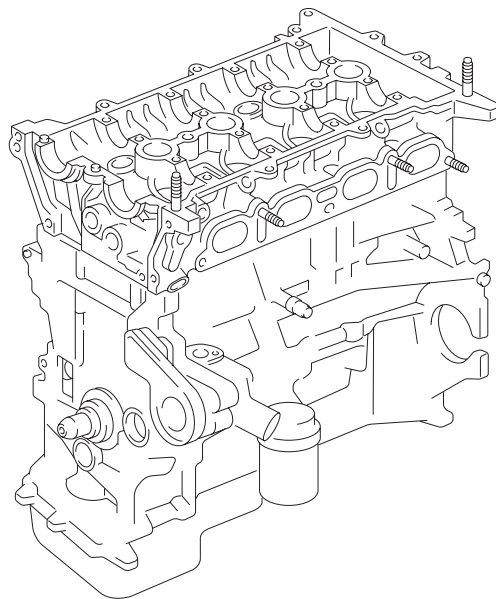
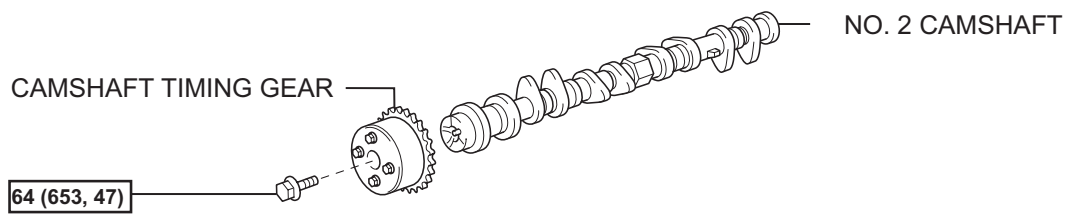
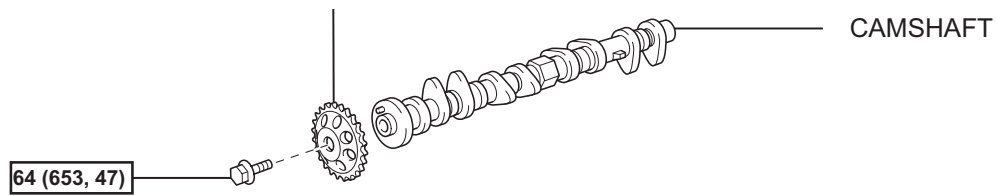

N*m (kgf*cm, ft.*lbf) : Specified torque

EM

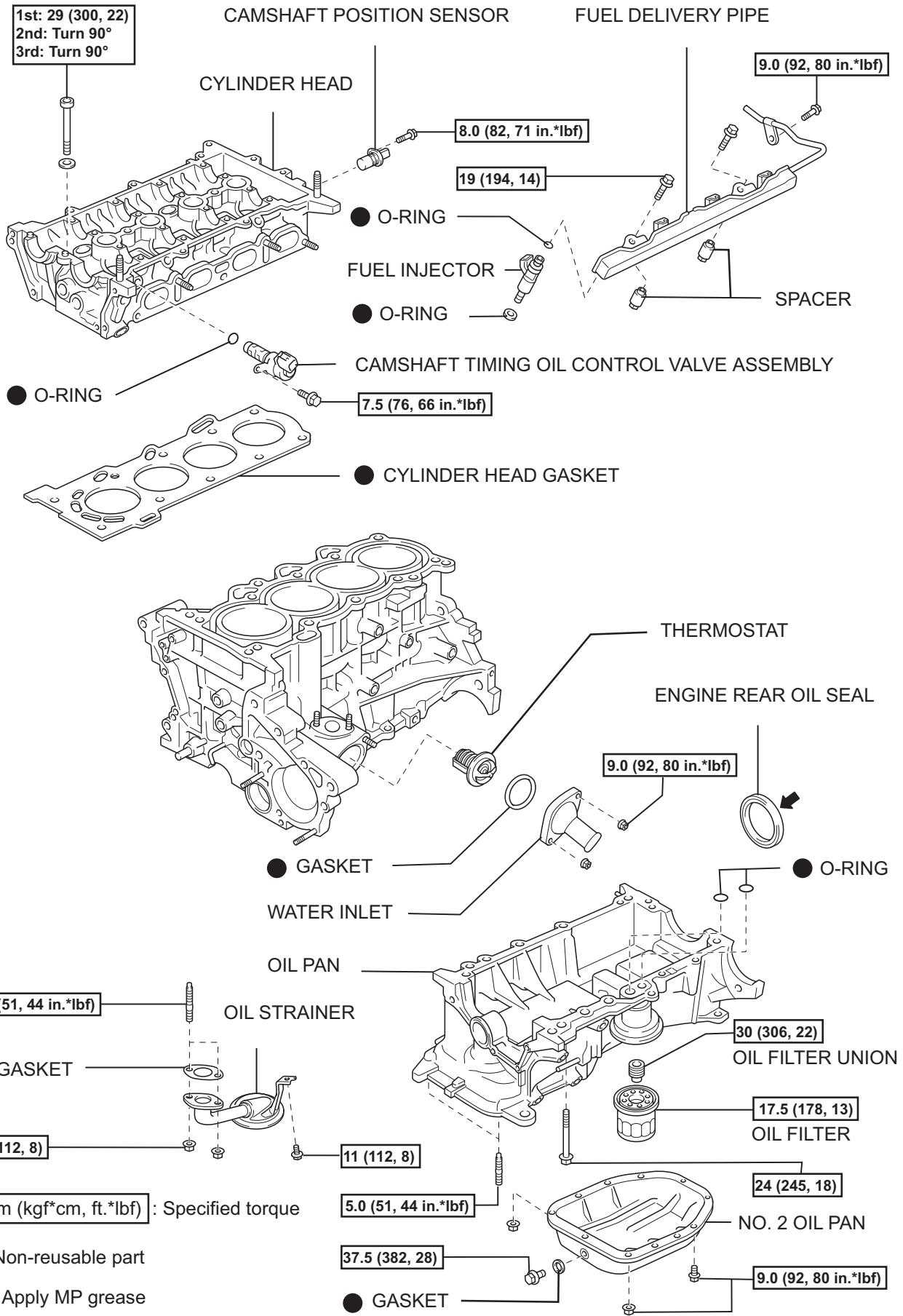

N*m (kgf*cm, ft.*lbf) : Specified torque

● Non-reusable part

◀ Apply MP grease

EM

EM

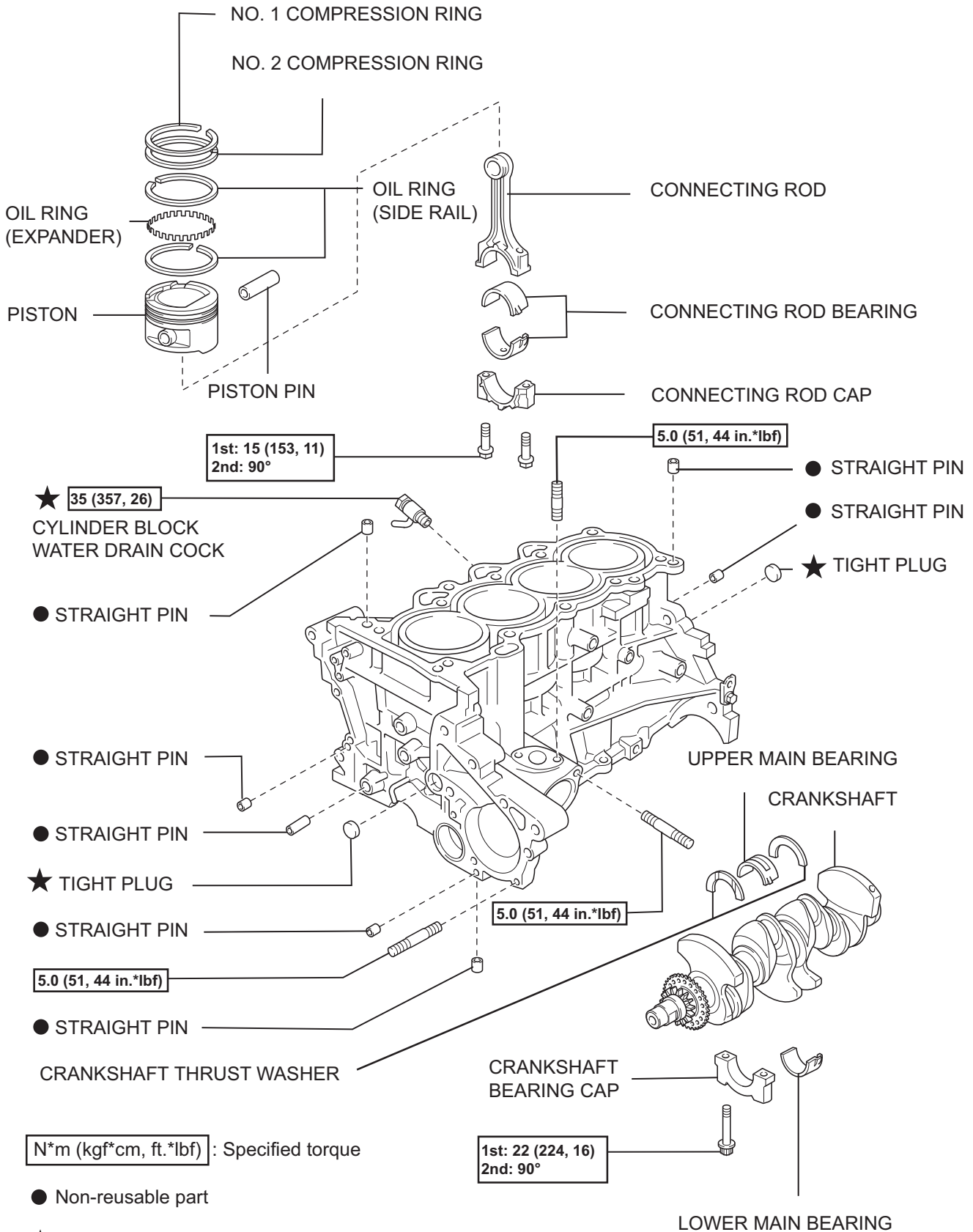

N*m (kgf*cm, ft.*lbf) : Specified torque

- Non-reusable part
- ★ Precoated part