

ON-VEHICLE INSPECTION

NOTICE:

In this section, the terms "cold" and "hot" refer to the temperature of the coils. "Cold" means approximately -10 to 50°C (14 to 122°F). "Hot" means approximately 50 to 100°C (122 to 212°F).

1. INSPECT IGNITION COIL ASSEMBLY AND SPARK TEST

- (a) Check for DTCs.

NOTICE:

If a DTC is present, perform troubleshooting in accordance with the procedure for that DTC.

- (b) Check that sparks occur.
- (1) Remove the No. 1 engine cover.
 - (2) Remove the ignition coil.
 - (3) Disconnect the 4 fuel injector connectors.

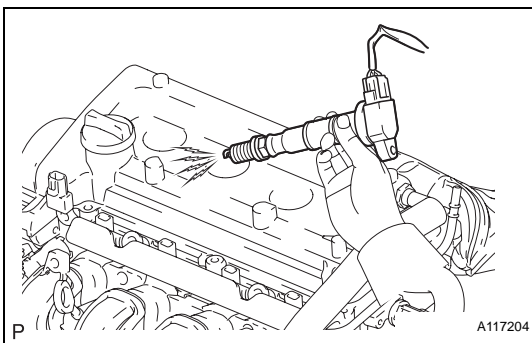
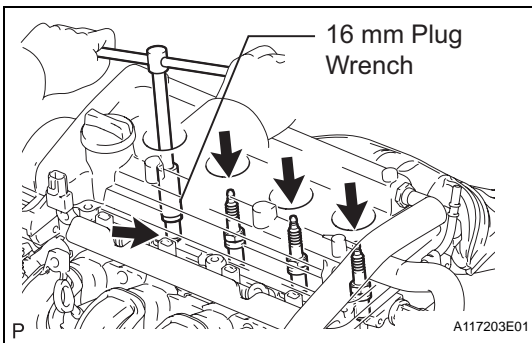
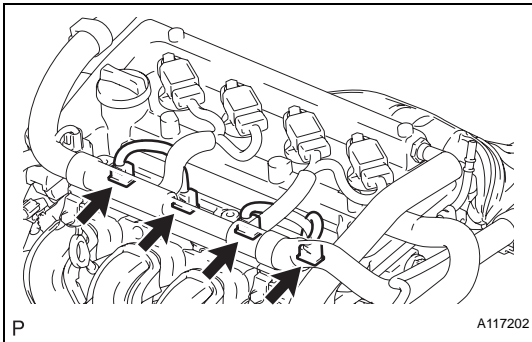

- (4) Using a 16 mm plug wrench, remove the 4 spark plugs.

Torque: 18 N*m (184 kgf*cm, 13 ft.*lbf)

- (5) Install each spark plug into an ignition coil, then connect the ignition coil connectors.
- (6) Ground the spark plugs.
- (7) Check that a spark occurs at each spark plug while the engine is being cranked.

NOTICE:

- Be sure to ground the spark plugs when checking.
- If the ignition coil has been struck or dropped, replace it.
- Do not crank the engine for more than 2 seconds.

If spark do not occur, perform the following procedure.

(c) Spark test flow chart.

- (1) Check that the wire harness side connector of the ignition coil is securely connected.

Result

Result	Proceed to
NG	Connect securely
OK	Go to next step

- (2) Perform the spark test on each ignition coil.
 1. Replace ignition coil with a normal one.
 2. Perform spark test again.

Result

Result	Proceed to
OK	Replace ignition coil
NG	Go to next step

- (3) Check the power supply to the ignition coil.
 1. Disconnect the ignition coil connector.
 2. Turn the ignition switch ON.
 3. Using a voltmeter, measure the voltage between the terminals.

Standard voltage

Tester Connection	Specified Condition
1 (+B) - 4 (GND)	9.0 to 14 V

Result

Result	Proceed to
NG	Check wire harness and connector (Between power switch and ignition coil assembly)
OK	Go to next step

- (4) Check the resistance of the the camshaft position sensor.

Standard resistance

Temperature	Specified Condition
Cold	1,630 to 2,740 Ω
Hot	1,060 to 1,645 Ω

Result

Result	Proceed to
NG	Replace camshaft position sensor
OK	Go to next step

- (5) Check the resistance of the crankshaft position sensor.

Standard resistance

Temperature	Specified Condition
Cold	985 to 1,600 Ω
Hot	1,265 to 1,890 Ω

Result

Result	Proceed to
NG	Replace crankshaft position sensor

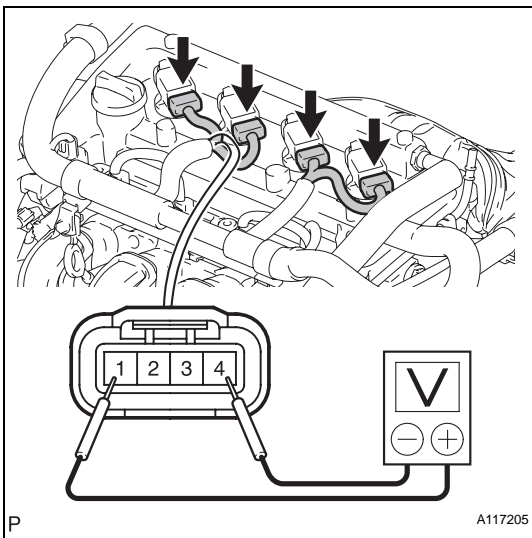

Result	Proceed to
OK	Go to next step

(6) Check the IGT signal from the ECM.

Result

Result	Proceed to
NG	Replace ECM
OK	Repair wire harness or connector (Between ignition coil assembly and ignition switch)

2. INSPECT SPARK PLUG

- (a) Remove the ignition coils (see page IG-8).
- (b) Using a 16 mm plug wrench, remove the 4 spark plugs.

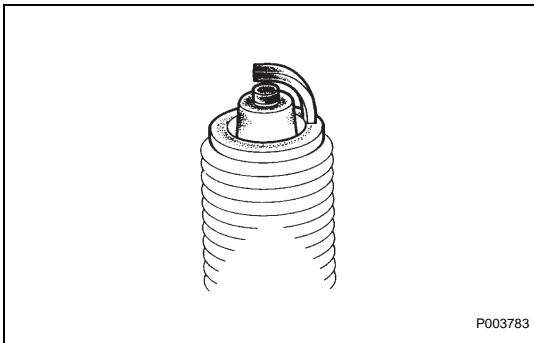
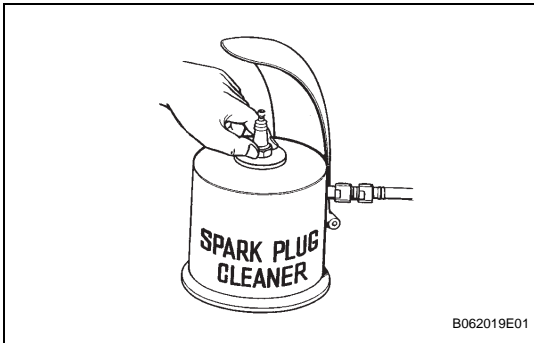
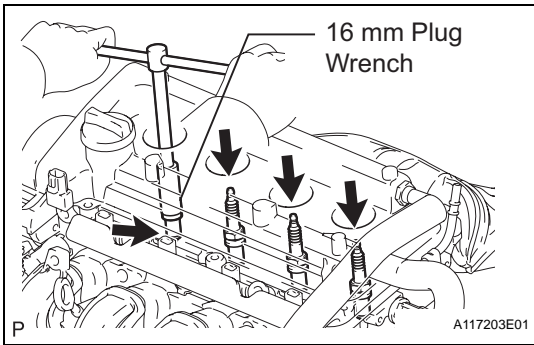

- (c) Clean the spark plugs.
If the electrode has traces of wet carbon, clean the electrode with a spark plug cleaner and then dry it.

Standard air pressure:

588 kPa (6 kgf/cm², 85 psi)

Standard duration:

20 seconds or less

- (d) Check the spark plug for any damage on its threads and insulator.
If there is damage, replace the spark plug. If not, reinstall the spark plug.

Recommended spark plug

Manufacturer	Product
DENSO	K16R-U
NGK	BKR5EYA

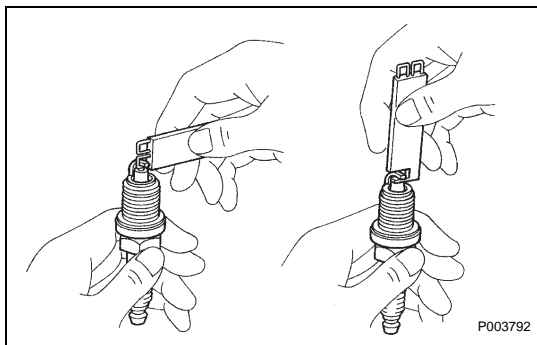

- (e) Inspect and adjust the electrode gap.
Standard electrode gap:
0.7 to 0.8 mm (0.028 to 0.031 in.)
- (f) Using a 16 mm plug wrench, install the 4 spark plugs.
Torque: 18 N*m (184 kgf*cm, 13 ft.*lbf)
- (g) Install the ignition coils (see page [IG-8](#)).